

S-Force Radials

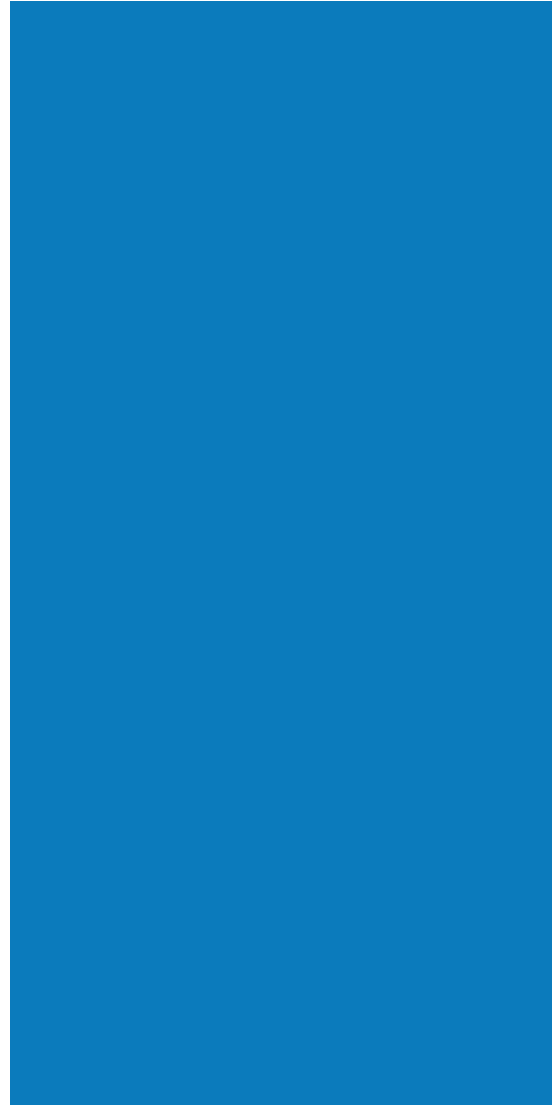

the engineers choice

ebmpapst

S-Force Radials



S-Force series RER120

S-Force series RER190

S-Force series RER175

S-Force series RER133

High Performance S-Force Radials

ebm-papst proudly extends the already successful S-Force generation of compact fans with the new S-Force Radial Blowers.

The high-powered S-Force Radials are backward-curved motorized impellers that yield substantially more airflow at elevated pressures, providing maximum cooling capacity in even the most complex and demanding of applications. The motors are ultra compact direct current motors integrated with wear-free electronic commutation, thus providing up to 89% efficiency with minimum noise and energy consumption.

The S-Force Radial Blowers are currently composed of six series, with sizes ranging from 120 mm to 225 mm. The high-performance air movers feature nominal speeds of up to 4,600 RPM and provide airflow of up to 988 CFM, far surpassing performance levels of any radial blowers currently available on the market.

The S-Force radial blowers are standard with PWM control input and speed signal. Optional features include speed monitoring, closed loop speed control, operation monitoring, integrated or external temperature sensor, and microprocessor controlled motor management for software controlled operation.

Applications for the new S-Force Radial Blowers include heat exchangers, fresh air filters for telecommunication cabinets, wireless electronic cabinets and many more. Find out how the new S-Force Radial Blowers can benefit your applications!

∅ 120 x 54mm

RER120DC Series



- 3-phase fan drive with high degree of smooth operation.
- High pressure build-up
- Backward-curved impeller
- Standard with PWM control input and speed signal, additional inputs and outputs on request.
- Fiberglass-reinforced plastic impeller
- Fully integrated electronic commutation
- Direction of rotation: CW as seen on rotor
- Direction of air flow: axial suction, radial air outlet
- Electrical connection via single leads AWG 20, TR 6. Stripped and tinned ends.

Part Number	Curve	CFM @ 0	VDC	Volt. Range	Power Input (W)	Bel	Max Amb. Temp C	Bearing Type	Features	Speed (RPM)	Wgt. (lbs.)
RER120-26/14/2TDP	1	221.9	24	6 to 32	78	8.2	75	Ball	Leads	6100	0.95
RER120-26/18/2TDP	2	229.5	48	36 to 60	92	8.2	75	Ball	Leads	6300	0.95

Speed control range from 800 rpm at 7 % PWM up to nominal speed at >90 % PWM. Stationary at 0% PWM, maximum speed at interruption of control wire.
Preliminary data, subject to alterations without notice.

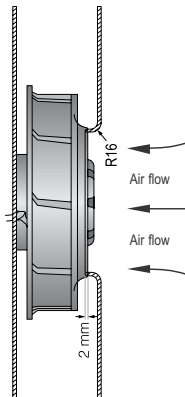

The air flow and noise level of fans without external housing depends on the installation conditions. The stated air flow and noise has been measured under the following conditions:
Centrifugal fan mounted on a base plate 140 x 140 mm.
Cover plate 140 x 140 mm with an air-inlet of ∅ 96 mm, concentric to the blower wheel.

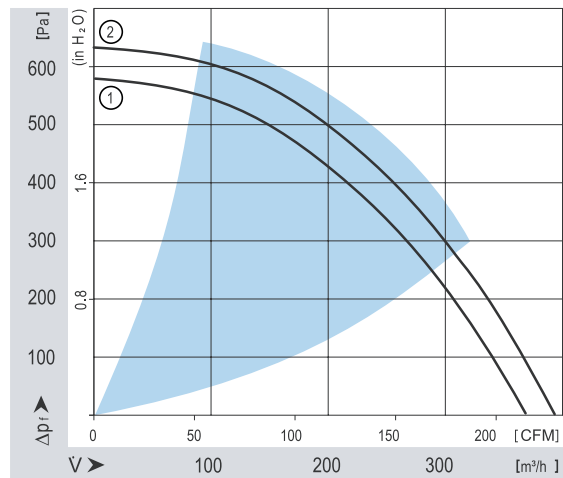
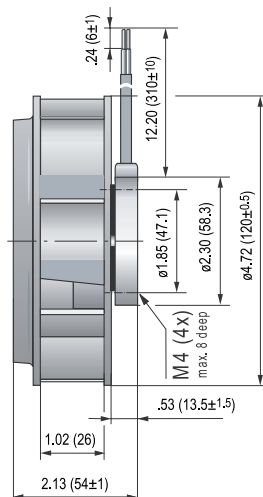
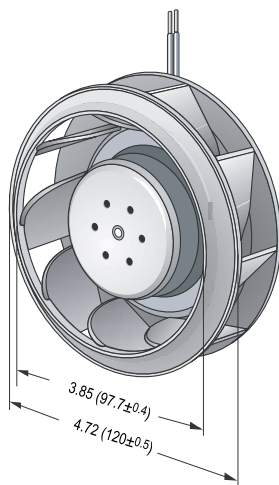

∅ 133 x 91mm

RER133DC Series



- 3-phase fan drive with high degree of smooth operation.
- High pressure build-up
- Backward-curved impeller
- Standard with PWM control input and speed signal, additional inputs and outputs on request.
- Fiberglass-reinforced plastic impeller
- Fully integrated electronic commutation
- Direction of rotation: CW as seen on rotor
- Direction of air flow: axial suction, radial air outlet
- Electrical connection via single leads AWG 22, TR 64. Stripped and tinned ends

Part Number	Curve	CFM @ 0	VDC	Volt. Range	Power Input (W)	Bel	Max. Amb. Temp C	Bearing Type	Features	Speed (RPM)	Wgt. (lbs)
RER133-41/18/2TDP	1	332.4	48	36 to 72	87	8.25	65	Ball	Leads	6000	1.96

Speed control range from 800 rpm at 7% PWM up to nominal speed at >90 % PWM. Stationary at 0% PWM, maximum speed at interruption of control wire.
Preliminary Data, subject to alterations without notice.

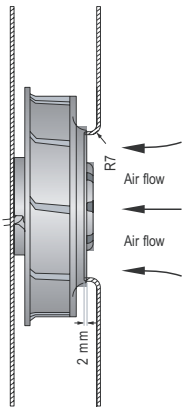

The air flow and noise level of fans without external housing depends on the installation conditions. The stated air flow and noise has been measured under the following conditions:
Centrifugal fan mounted on a base plate 140 x 140 mm.
Cover plate 140 x 140 mm with an air-inlet of ∅ 87 mm, concentric to the blower wheel.

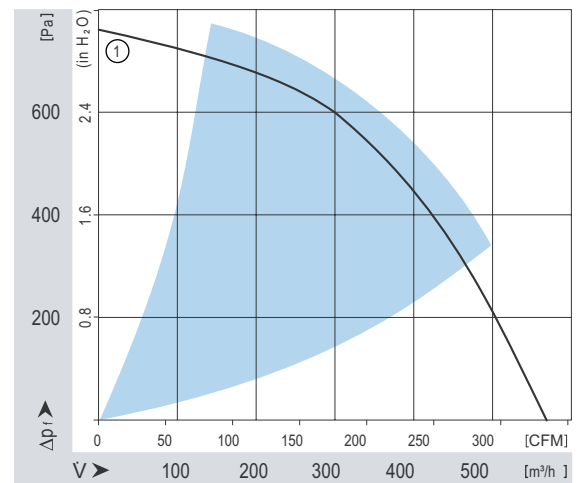
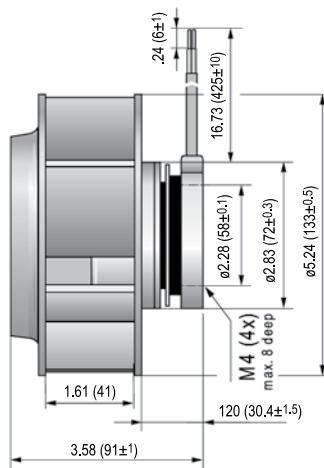
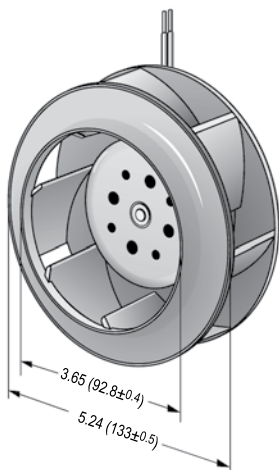

∅ 175 x 69mm

RER175DC Series



- 3-phase fan drive with high degree of smooth operation.
- High pressure build-up
- Backward-curved impeller
- Standard with PWM control input and speed signal, additional inputs and outputs on request.
- Fiberglass-reinforced plastic impeller
- Fully integrated electronic commutation
- Direction of rotation: CW as seen on rotor
- Direction of air flow: axial suction, radial air outlet
- Electrical connection via single leads AWG 20, TR 64, speed signal and control input AWG 22. Stripped and tinned ends

Part Number	Curve	CFM @ 0	VDC	Volt. Range	Power Input (W)	Bel	Max. Amb. Temp C	Bearing Type	Features	Speed (RPM)	Wgt. (lbs)
RER175-42/18/2TDMLP	1	353.0	48	36 to 65	42	tbd	65	Ball	Leads	3400	1.71
RER175-42/18/2TDP	2	576.8	48	36 to 72	166	8.5	65	Ball	Leads	5400	1.71

Speed control range from 800 rpm at 7% PWM up to rpm at > 90% PWM. Stationary at 0% PWM, maximum speed at interruption of control wire. Preliminary data, subject to alterations without notice.

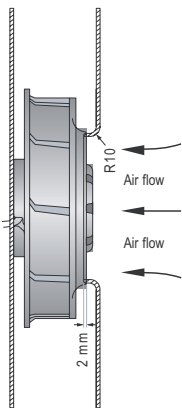

The air flow and noise level of fans without external housing depends on the installation conditions. The stated air flow and noise has been measured under the following conditions:
 Centrifugal fan mounted on a base plate 180 x 180 mm.
 Cover plate 180 x 180 mm with an air-inlet of ∅ 125.5 mm, concentric to the blower wheel.

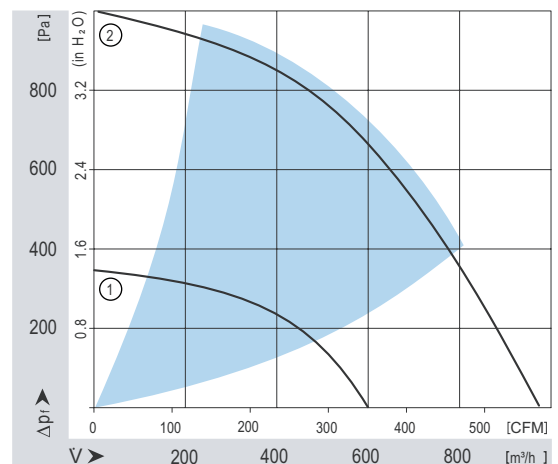
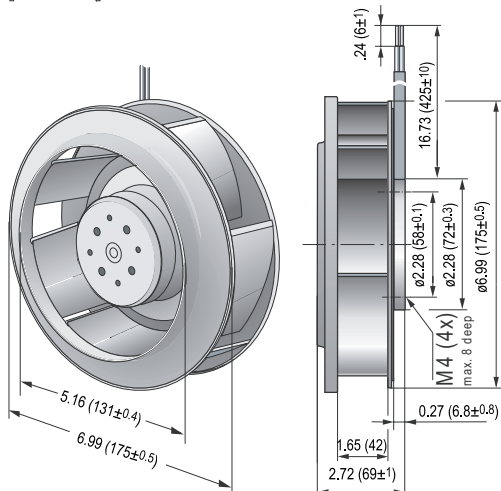

ebm-papst Inc. USA

100 Hyde Road
Farmington CT 06034
Phone: +1-860-674-1515
Fax: +1-860-674-8536
sales@us.ebmpapst.com
www.ebmpapst.us

the engineers choice

ebmpapst